

NEW



EAN code
 PRI-34/1A: 8595188188968
 PRI-34/2A: 8595188182829
 PRI-34/5A: 8595188182836
 PRI-34/8A: 8595188188975
 PRI-34/16A: 8595188182843

Technical parameters

PRI-34

Supply

Supply terminals:	A1 – A2
Supply voltage:	AC/DC 24 – 240 V (AC 50-60 Hz)
Consumption (max.):	3.8 VA/0.7 W
Supply voltage tolerance:	-15 %; +10 %

Measuring circuit

Current range:	PRI-34/1A In - 1A PRI-34/2A In - 2A PRI-34/5A In - 5A PRI-34/8A In - 8A PRI-34/16A In - 16A (AC 50-60 Hz)
Max. permanent current/ peak overload (1 s):	PRI-34/1A 2A/10A PRI-34/2A 4A/10A PRI-34/5A 10A/16A PRI-34/8A 16A/16A PRI-34/16A 17A/32A
Current setting (Imax):	10 – 100 %In
Current setting (Imin):	5 – 95 %In
Time delay (d):	300 ms
Time delay (t):	adjustable, 0.5 – 10 s

Accuracy

Setting accuracy (mech.):	5 %
Repeatable accuracy:	< 1 %
Temperature dependency:	< 0.1 %/°C
Limit values tolerance:	5 %
Hysteresis (fault to OK):	5 % (function O1, U1, W) Imax – Imin (function O2, U2)

Output

Number of contacts:	1x changeover (AgNi)
Current rating:	16 A/AC1
Breaking capacity:	4000 VA/AC1, 384 W/DC1
Switching voltage:	250 V AC/24 V DC
Power dissipation (max.):	1.2 W
Mechanical life:	10.000.000 ops.
Electrical life (AC1):	100.000 ops.

Other information

Operating temperature:	-20 .. +55 °C (-4 °F .. 131 °F)
Storage temperature:	-30 .. +70 °C (-22 °F .. 158 °F)
Dielectric strength:	AC 4 kV (supply – output)
Operating position:	any
Mounting:	DIN rail EN 60715
Protection degree:	IP40 front panel / IP20 terminals
Overvoltage category:	III.
Pollution degree:	2
Cross-wire section – solid/ stranded with ferrule (mm ²):	max. 1x 2.5, 2x 1.5/ max. 1x 2.5 (AWG 14)
Dimensions:	90 × 17.6 × 64 mm (3.5" × 0.7" × 2.5")
Weight:	60 g (2.15 oz.)
Standards:	EN 60255-1, EN 60255-26, EN 60255-27

- It is used to monitor the value of alternating current, e.g.: motors, heating cables, lamps and other devices.
- Power supply and monitoring circuits are not galvanically isolated.
- Monitors current exceeding the upper current limit (Imax) and falling below the lower current limit (Imin) – according to the selected function.
- Smooth adjustment of both current limits.
- Adjustable time delay (to eliminate short-term current spikes).
- Option to select functions with fault state memory (Latch).
- Measures true root mean square value of the current - TRUE RMS.
- Possibility to extend the current range using an external current transformer.

Description

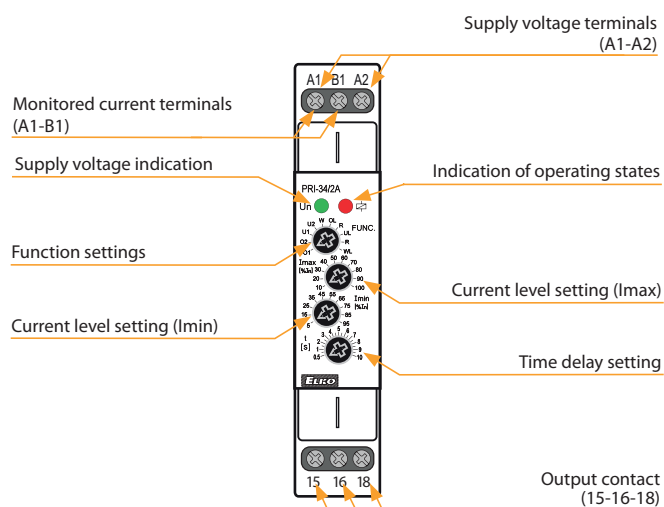

Connection

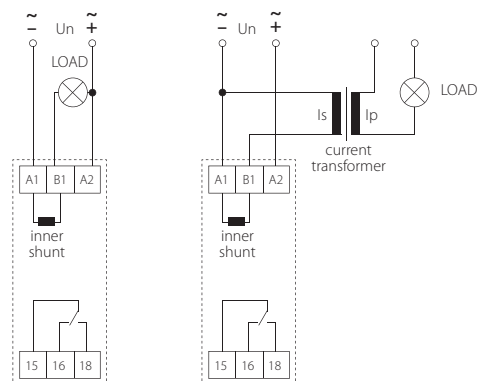

Indication of operating states

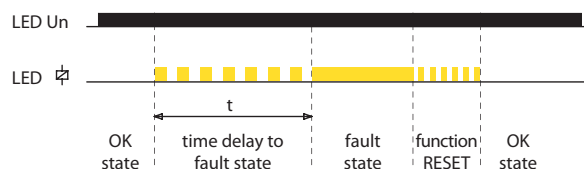

Function

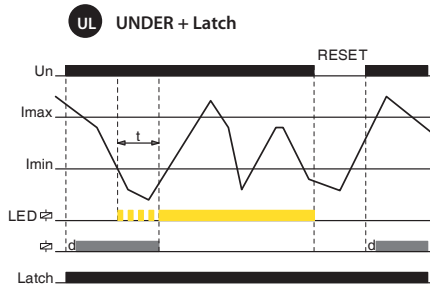
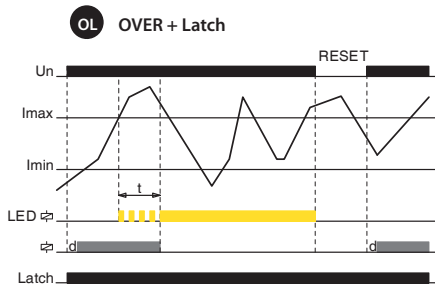
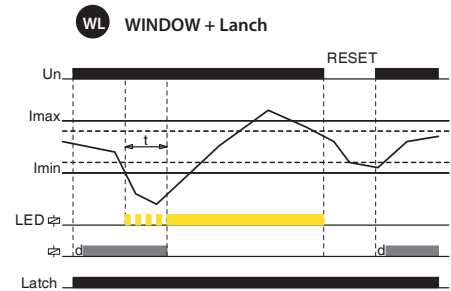
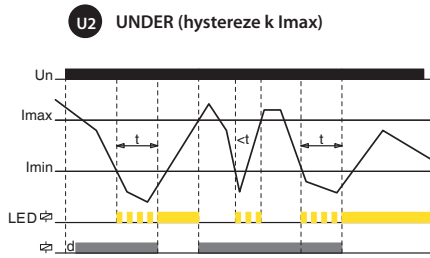
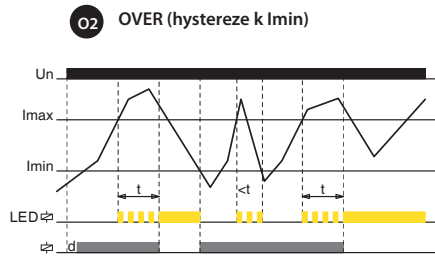
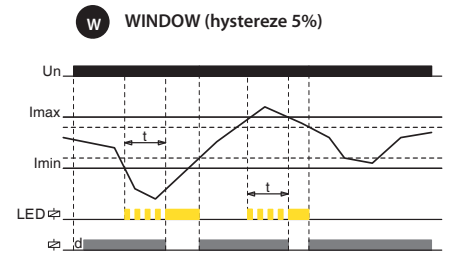
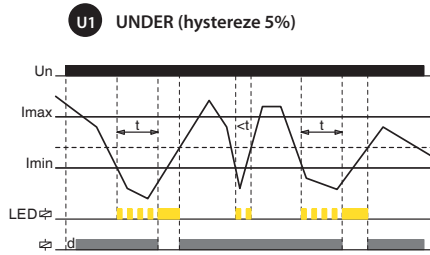
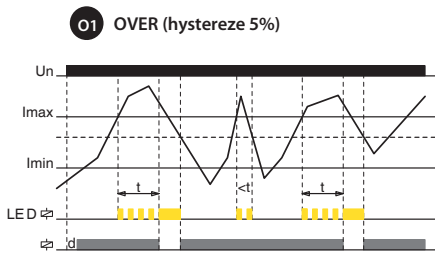

Graphs legend:
 t = time delay to fault state
 d = delay 0.3 s after connection of power supply (Un)
 H = hysteresis

OVER:

- If the amount of the monitored current is lower than the set limit „Imax”, the output contact is closed. If the „Imax” is exceeded, the output contact will open after the set delay (fault state).
- If the current falls below the fixed hysteresis (function O1) or the set lower limit (function O2), the output contact will closes again.
- If the OL function (OVER + Latch) is selected, when the current „Imax” is exceeded, the output contact remains open even when the current returns from the fault state.

Fault memory reset can be done in two ways:

- Short-term interruption of supply voltage.
- By setting the function switch to position R (RESET) or any function without memory fault.

The RESET state lasts for 3 s after switching the function switch from the R position to a function with memory fault (UL, OL, WL).

When moving to any other function from the R position, this delay does not apply.

UNDER:

- If the amount of the monitored current is higher than the set limit „Imin”, the output contact is closed. When the current drops below the „Imin”, output contact opens after the set delay (fault state).
- If the current exceeds the fixed hysteresis (function U1) or the set upper limit (function U2), the output contact closes again.
- If the UL function (UNDER + Latch) is selected, when the current drops below „Imin”, the output contact remains open even when returning from the fault state. Fault memory reset can be done as in the previous case.

WINDOW:

- If the amount of the monitored current is lower than „Imax” and at the same time higher than „Imin”, the output contact in closed. If the „Imax” is exceeded or drop below the „Imin”, output contact opens after the set delay (fault state).
- To return from the fault state, a fixed hysteresis is applied.
- If the WL function (WINDOW + Latch) is selected, the fault state is stored in memory again even when returning from the fault state. Fault memory reset can be done as in the previous cases.